

Advertisement guidelines 2012

Terms and conditions

Page 2

- Deadline dates
- Cancellations
- Position
- Alterations
- Variations in colour
- Advertising agencies
- Advertisement material archive
- Payment

How to get your digital material to us

Page 3

Advertisement specifications

False front cover	4
Double page spread (DPS)	5
Full page	6
A5	7
Half page VERTICAL	8
Third page VERTICAL	9
Half page HORIZONTAL	10
Third page HORIZONTAL	11
Quarter page VERTICAL	12
Quarter page HORIZONTAL	13
Strip	14
Directory advertisement sizes	15
E-mail bulletin advertisement	16
Bellybands	17

Basic problems with advertisement material explained

The difference between a bleed and a floating advertisement	18
No bleed	18
Text too close to the cutting edge	18
RGB files	19
Bitmapping/Pixelating/Low resolution	19

Who can make up my advertisement material?

Page 19

Brooke Patrick Studio

Terms and conditions

Booking deadline: First day of the month prior to the month of publication (NB: no cancellations will be accepted after this date) A surcharge will be levied for cancellations of contract bookings.

Material deadline: Fifth day of the month prior to month of publication.

For new clients: A deposit of 30% is required, based on the total of the confirmed quote. During this time, the account will be monitored and if payments of invoices are received timeously, the debtor will qualify for a 30-day account from the date of the invoice. The deposit will be offset against the final payment required. Once-off bookings require a 50% deposit.

Payment is strictly 30 days for direct bookings, and 45 days for advertisement agency bookings, from the date of statement. Interest will be charged at a rate of prime plus 3% per annum on outstanding accounts

Cancellations will only be accepted in writing (with the onus of proof resting with the advertiser) and received by no later than the 1st of the month prior to the month of publication. If any advertisements are cancelled and not replaced during the course of the contract, a surcharge must be made in accordance with our rate card.

In the event that **material does not reach us on time** as instructed on the advertisement confirmation letter, Brooke Patrick Publications reserves the right to repeat old material, or to charge the client for the advertisement without it appearing, or to place the advertisement in a future edition of the same magazine.

Special positions and frontcover alternatives cannot be cancelled once confirmed. No position can be guaranteed, unless the advertiser has paid a surcharge or if it is a cover booking.

Brooke Patrick Publications accepts no responsibility for slight **variations in colour** on advertisements.

Brooke Patrick Publications accepts no responsibility for advertisements that are supplied without a **colour proof**.

Advertisement material must be supplied in **digital format** as stipulated and will be kept in the advertisement material archive for a period of no longer than six months from the date of that material's final insertion.

Standard production rates apply for any additional work required to make digital work press-ready, including converting open files or resizing advertisements.

Alterations will be charged for.

Should an **advertising agency** be contracted to manage direct bookings, the value of the initial booking may not be diminished.

Agency Commission – Agencies forfeit ALL commission if payment is not received within 45 days from the invoice date.

How to get your material to us

Deadline dates

Material deadline

We must receive your material no later than the 5th day of the month prior to the month of publication.
You are welcome to send your material earlier.

- In the event that material does not reach us on time, as instructed on the advertisement confirmation letter, Brooke Patrick Publications reserves the right to repeat old material, or to charge the client for the advertisement without it appearing, or to place the advertisement in a future edition of the same magazine.

Options available for sending material to us:

E-mail
Websend
Delivery/Courier
Post

E-mail address

dtp@brookepatrick.co.za

Websend

You can contact websend for more information:
<http://www.websend.co.za/websend/>
Paolo Aceto (IT manager/technical support on newspapers and magazines)
Cell: 082 339 5832
paolo@wsd.co.za

FTP

Use an FTP client or Windows Explorer, do not use Internet Explorer.
External Link: <ftp://196.214.135.75/>
U/N: ftpuser
P/W: FTPuser99

Physical address

Building #13
Pinewood Office Park
33 Riley Road
Woodmead
Johannesburg

Postal address

Private Bag X40
Rivonia
2128

Magazine ad

False

Covers

Booking Deadline

First day of the month prior to the month of publication.

Material Deadline

Fourth day of the month prior to the month of publication.

- Files can be supplied on **CD, DVD, websend** or via **e-mail** (e-mail file not exceeding 8 MB).
- Advertisements can be e-mailed to **ntp@brookepatrick.co.za**

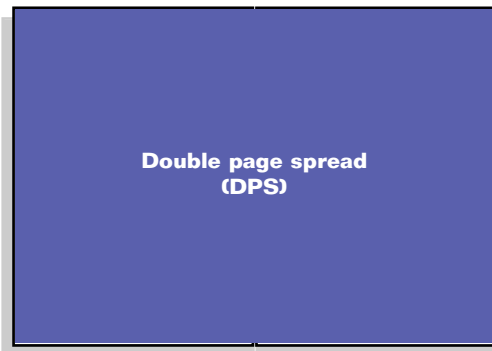

BROOKE PATTRICK
P U B L I C A T I O N S

Outside cover

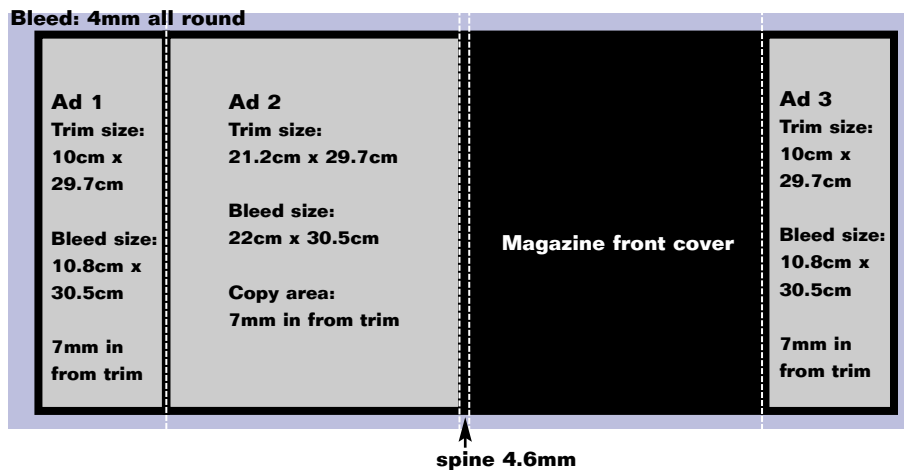

Inside cover

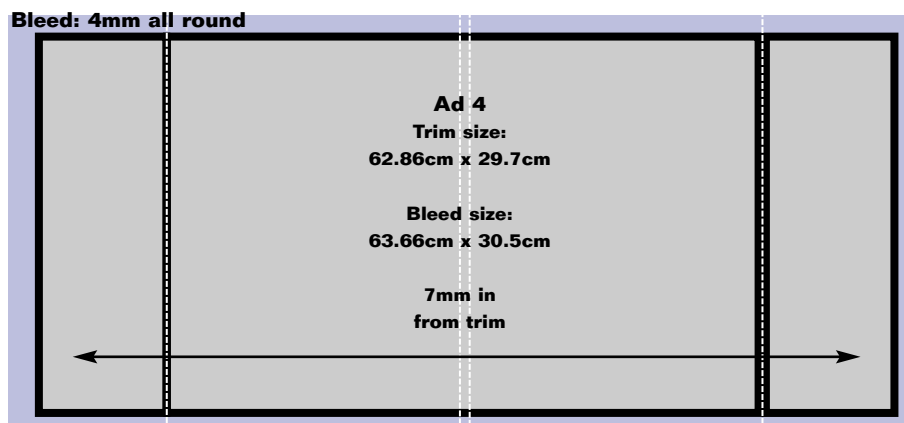

Reproduction material

- **Digital files required** - **PDF** (Closed, all fonts included, press-optimised PDF file, PDF/X-1a:2001)
 - **Tiff** (300 dpi Tiff (CMYK, real advertisement size)
 - **JPG** (300 dpi JPG, highest quality (CMYK, real advertisement size)

Brooke Patrick Publications can ONLY accept these three file types.

- **Crop marks**

All digital files must be supplied with crop marks. Crop marks must show the trim size.

A conversion rate of R350 will be applicable if the advertisements must be re-sized or are supplied without crop marks.

- **Bleed**

All files must have 4 mm bleed.

- **Colour correct proof**

A colour proof of the advertisement must be submitted. Brooke Patrick Publications accepts no responsibility for colour variations in advertisements that are supplied without a colour correct proof.

Advertisement specifications

- Files can be supplied on **CD, DVD, websend** or via **e-mail** (e-mail file not exceeding 8 MB).
- Advertisements can be e-mailed to **ntp@brookepatrick.co.za**

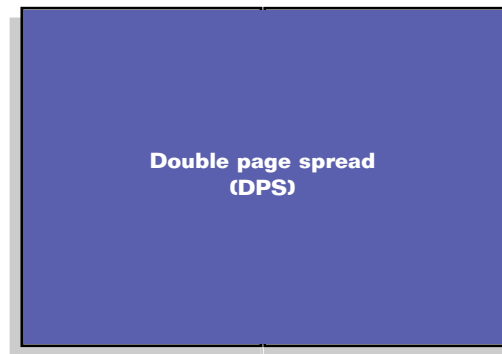

BROOKEPATTRICK
P U B L I C A T I O N S

Bleed advertisement

Ensure no text flows into the spine of the magazine as this will be illegible after binding.

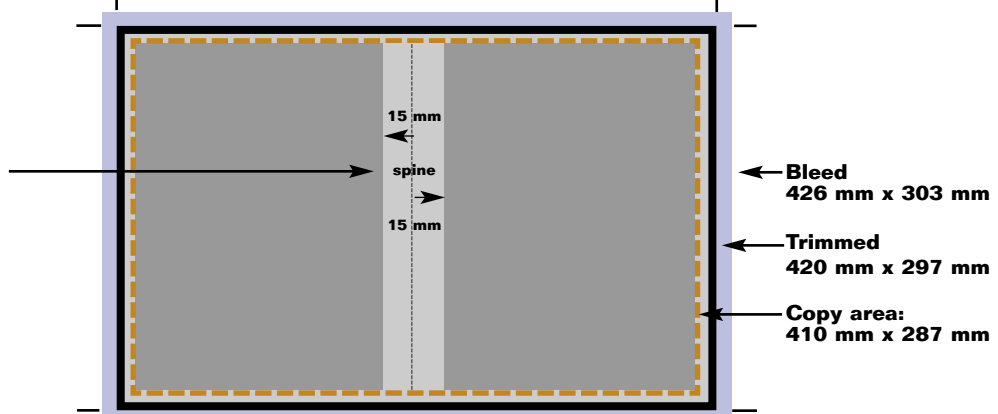

“Floating” advertisement

Ensure no text flows into the spine of the magazine as this will be illegible after binding.

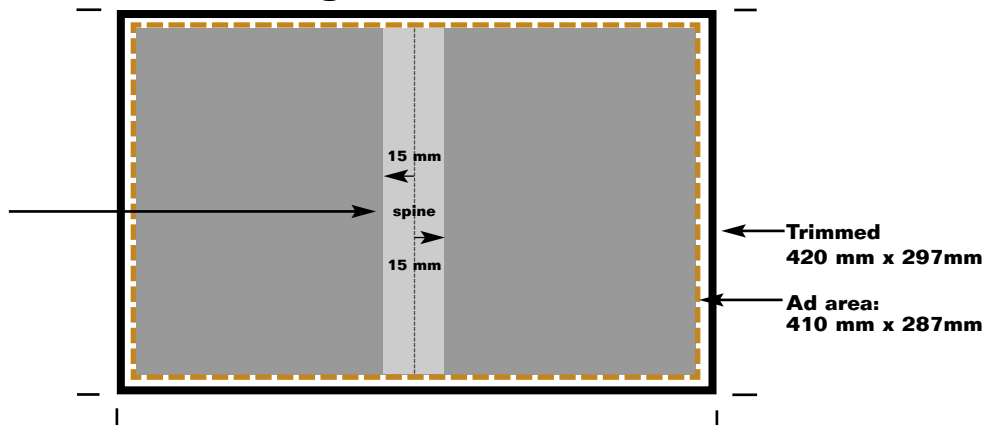

Reproduction material

- **Digital files required** - **PDF** (Closed, all fonts included, press-optimised PDF file, PDF/X-1a:2001)
- **Tiff** (300 dpi Tiff (CMYK, real advertisement size)
- **JPG** (300 dpi JPG, highest quality (CMYK, real advertisement size)

Brooke Patrick Publications can ONLY accept these three file types.

- **Crop marks**

All digital files must be supplied with crop marks. Crop marks must show the trim size.

A conversion rate of R350 will be applicable if the advertisements must be re-sized or are supplied without crop marks.

- **Bleed**

All files must have 3 mm bleed.

- **Colour correct proof**

A colour proof of the advertisement must be submitted. Brooke Patrick Publications accepts no responsibility for colour variations in advertisements that are supplied without a colour correct proof.

Advertisement specifications

- Files can be supplied on **CD, DVD, websend** or via **e-mail** (e-mail file not exceeding 8 MB).
- Advertisements can be e-mailed to **dtp@brookepatrick.co.za**

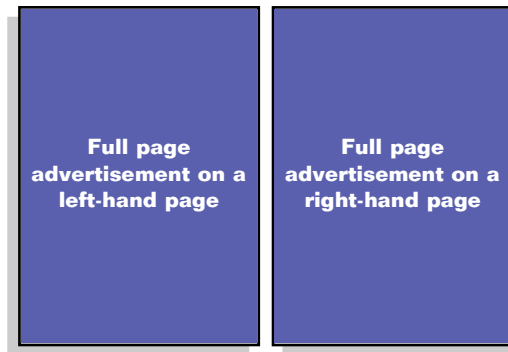

Magazine advertisement

Full page

PORTRAIT

210 mm x 297 mm

Booking Deadline

1st day of the month prior to the month of publication.

Material Deadline

5th day of the month prior to the month of publication.

BROOKE PATTRICK
P U B L I C A T I O N S

Bleed advertisement

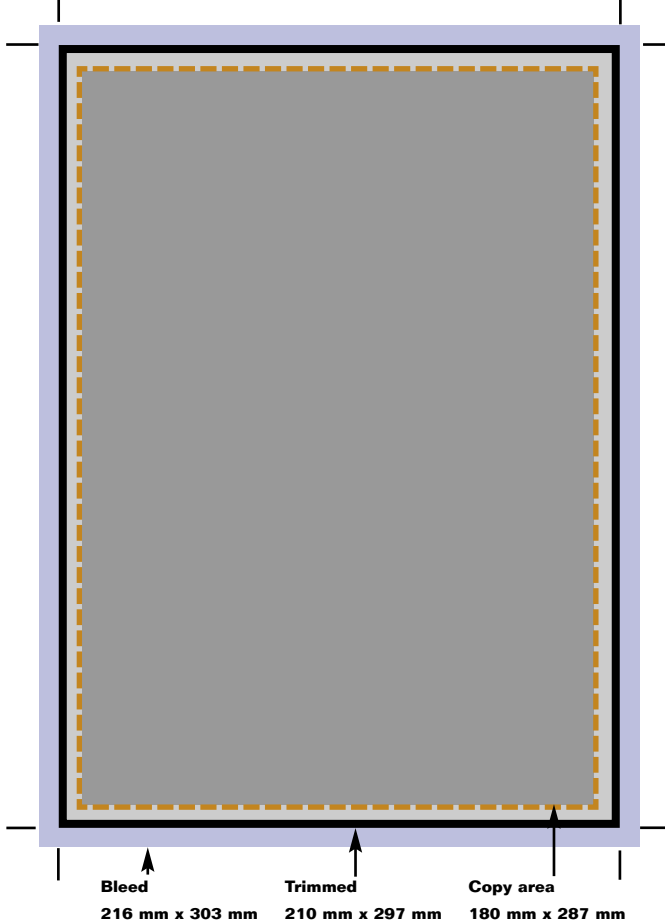

“Floating” advertisement

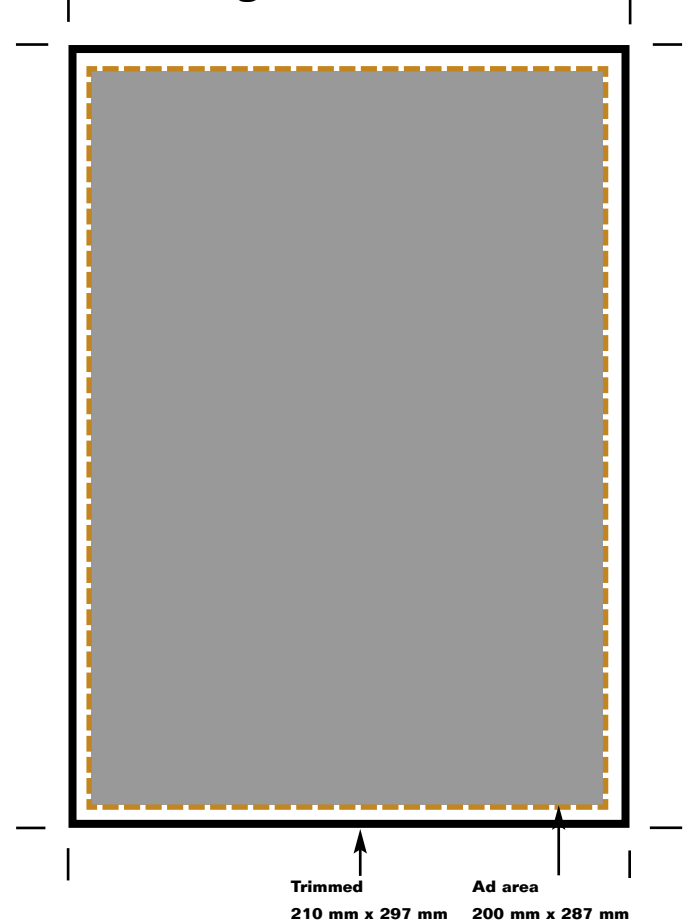

Reproduction material

- **Digital files required** - **PDF** (Closed, all fonts included, press-optimised PDF file, PDF/X-1a:2001)
- **Tiff** (300 dpi Tiff (CMYK, real advertisement size)
- **JPG** (300 dpi JPG, highest quality (CMYK, real advertisement size)

Brooke Patrick Publications can ONLY accept these three file types.

- **Crop marks**

All digital files must be supplied with crop marks. Crop marks must show the trim size.

A conversion rate of R350 will be applicable if the advertisements must be re-sized or are supplied without crop marks.

- **Bleed**

All files must have 3 mm bleed.

- **Colour correct proof**

A colour proof of the advertisement must be submitted. Brooke Patrick Publications accepts no responsibility for colour variations in advertisements that are supplied without a colour correct proof.

- Files can be supplied on **CD, DVD, Websend** or via **e-mail** (e-mail file not exceeding 8MB)
- Advertisements can be e-mailed to **dtp@brookepatrick.co.za**

Magazine ad
A5
VERTICAL
210x148mm
Booking Deadline First day of the month prior to the month of publication.
Material Deadline Fourth day of the month prior to the month of publication.

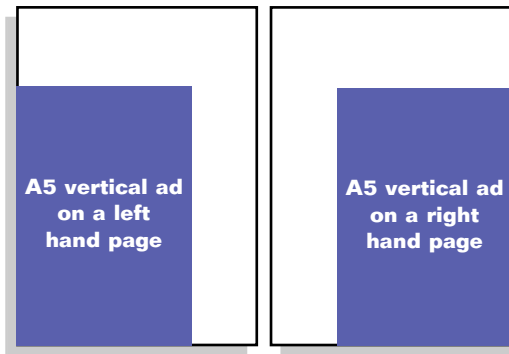

Bleed advertisement

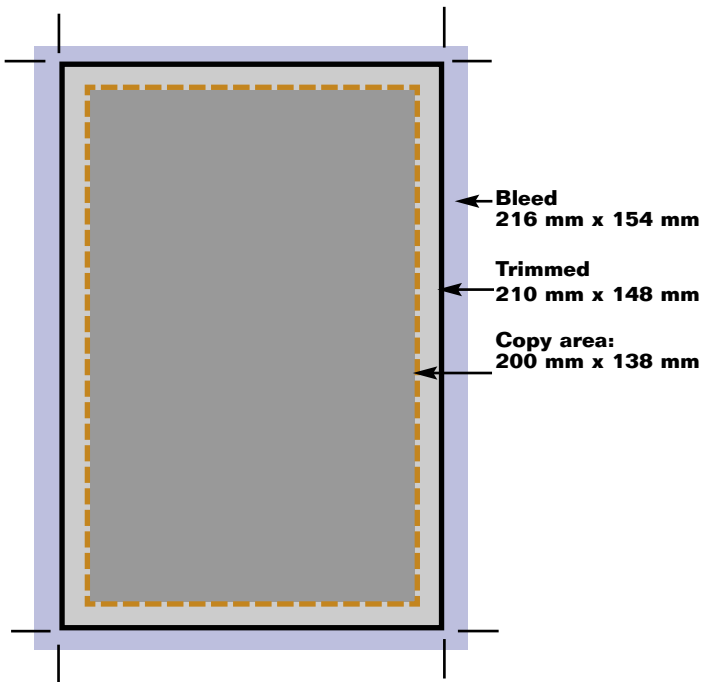

“Floating” advertisement

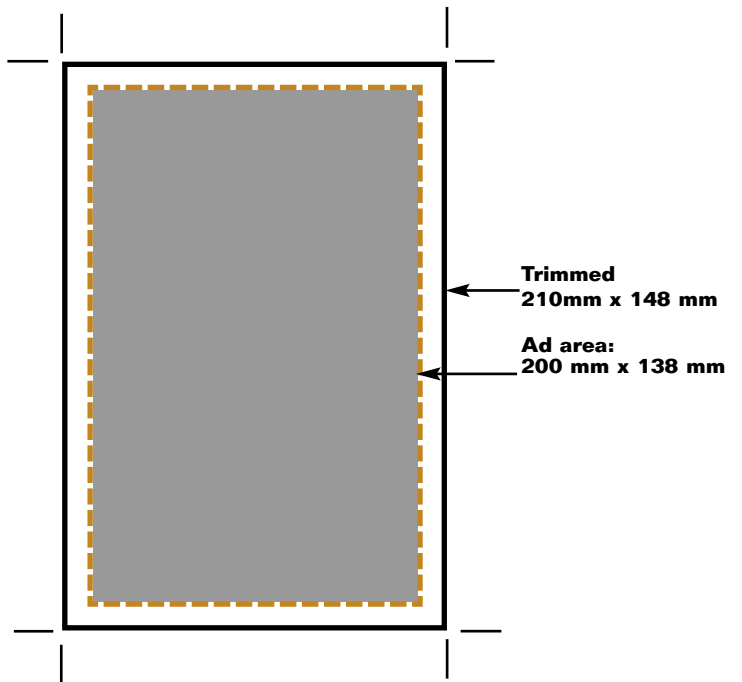

Reproduction material

- **Digital files required** - **PDF** (Closed, all fonts included, press-optimised PDF file, PDF/X-1a:2001)
- **Tiff** (300 dpi Tiff (CMYK, real advertisement size)
- **JPG** (300 dpi JPG, highest quality (CMYK, real advertisement size)

Brooke Patrick Publications can ONLY accept these three file types.

- **Crop marks**

All digital files must be supplied with crop marks. Crop marks must show the trim size.

A conversion rate of R350 will be applicable if the advertisements must be re-sized or are supplied without crop marks.

- **Bleed**

All files must have 3 mm bleed.

- **Colour correct proof**

A colour proof of the advertisement must be submitted. Brooke Patrick Publications accepts no responsibility for colour variations in advertisements that are supplied without a colour correct proof.

Advertisement specifications

- Files can be supplied on **CD, DVD, websend** or via **e-mail** (e-mail file not exceeding 8 MB).
- Advertisements can be e-mailed to **dtp@brookepatrick.co.za**

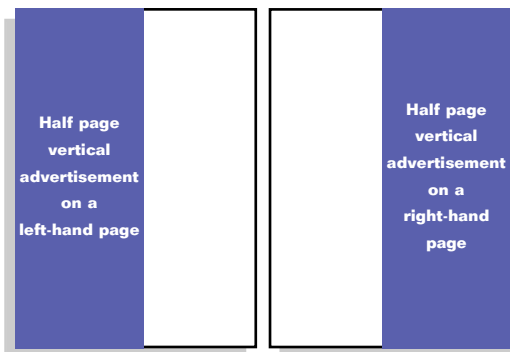

Magazine advertisement

Half page

VERTICAL

297 mm x 100 mm

Booking Deadline

1st day of the month prior to the month of publication.

Material Deadline

5th day of the month prior to the month of publication.

BROOKE PATTRICK
P U B L I C A T I O N S

Bleed advertisement

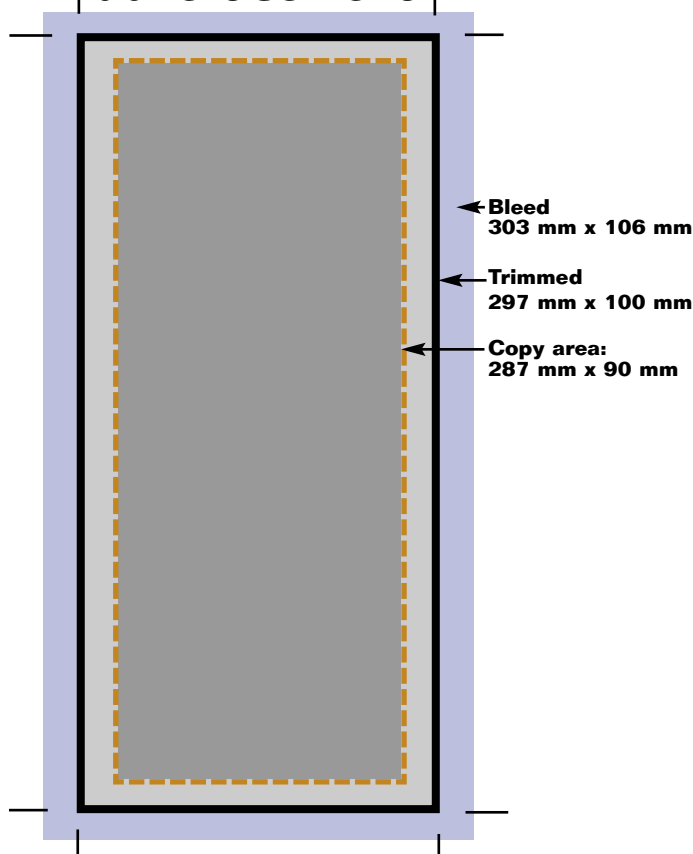

“Floating” advertisement

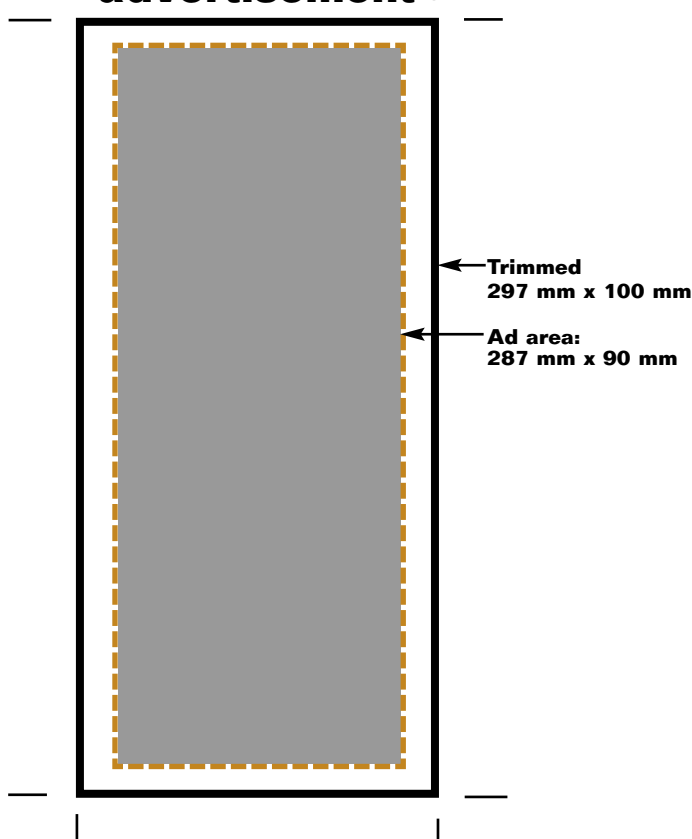

Reproduction material

- **Digital files required** - **PDF** (Closed, all fonts included, press-optimised PDF file, PDF/X-1a:2001)
 - **Tiff** (300 dpi Tiff (CMYK, real advertisement size)
 - **JPG** (300 dpi JPG, highest quality (CMYK, real advertisement size)

Brooke Patrick Publications can ONLY accept these three file types.

- **Crop marks**

All digital files must be supplied with crop marks. Crop marks must show the trim size.

A conversion rate of R350 will be applicable if the advertisements must be re-sized or are supplied without crop marks.

- **Bleed**

All files must have 3 mm bleed.

- **Colour correct proof**

A colour proof of the advertisement must be submitted. Brooke Patrick Publications accepts no responsibility for colour variations in advertisements that are supplied without a colour correct proof.

Advertisement specifications

- Files can be supplied on **CD, DVD, websend** or via **e-mail** (e-mail file not exceeding 8 MB).
- Advertisements can be e-mailed to **ntp@brookepatrick.co.za**

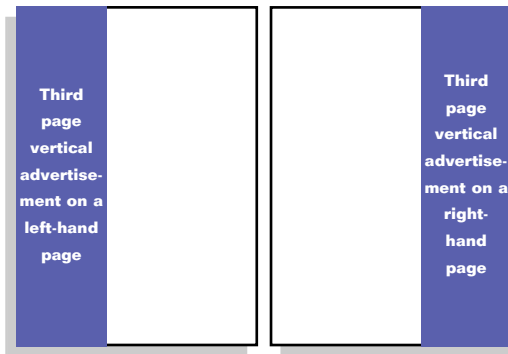

BROOKE PATTRICK
P U B L I C A T I O N S

Magazine advertisement

Third page

VERTICAL

297 mm x 65 mm

Booking Deadline

1st day of the month prior to the month of publication.

Material Deadline

5th day of the month prior to the month of publication.

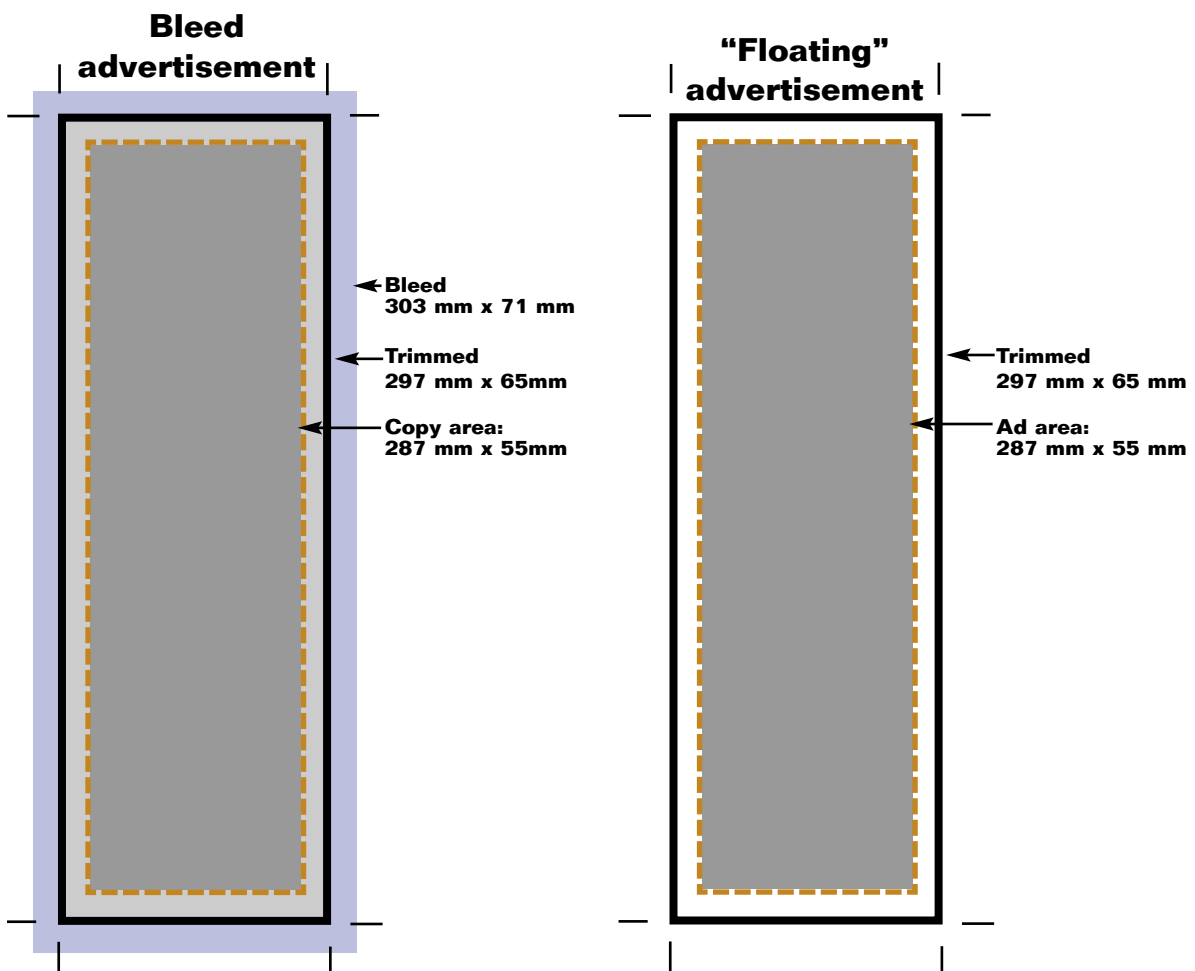

Reproduction material

- **Digital files required** - **PDF** (Closed, all fonts included, press-optimised PDF file, PDF/X-1a:2001)
- **Tiff** (300 dpi Tiff (CMYK, real advertisement size)
- **JPG** (300 dpi JPG, highest quality (CMYK, real advertisement size)

Brooke Pattrick Publications can ONLY accept these three file types.

- **Crop marks**

All digital files must be supplied with crop marks. Crop marks must show the trim size.

A conversion rate of R350 will be applicable if the advertisements must be re-sized or are supplied without crop marks.

- **Bleed**

All files must have 3 mm bleed.

- **Colour correct proof**

A colour proof of the advertisement must be submitted. Brooke Pattrick Publications accepts no responsibility for colour variations in advertisements that are supplied without a colour correct proof.

Advertisement specifications

- Files can be supplied on **CD, DVD, websend** or via **e-mail** (e-mail file not exceeding 8 MB).
- Advertisements can be e-mailed to **ntp@brookepatrick.co.za**

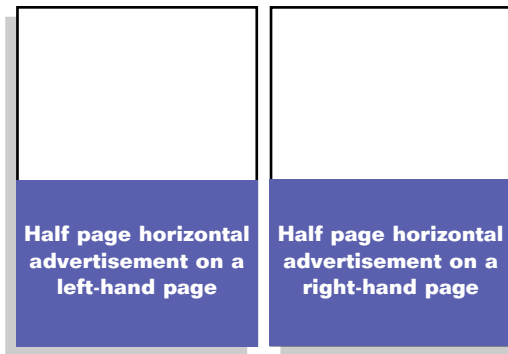

Magazine advertisement

Half page

HORIZONTAL

140 mm x 210 mm

Booking Deadline

1st day of the month prior to the month of publication.

Material Deadline

5th day of the month prior to the month of publication.

BROOKE PATTRICK
P U B L I C A T I O N S

Bleed advertisement

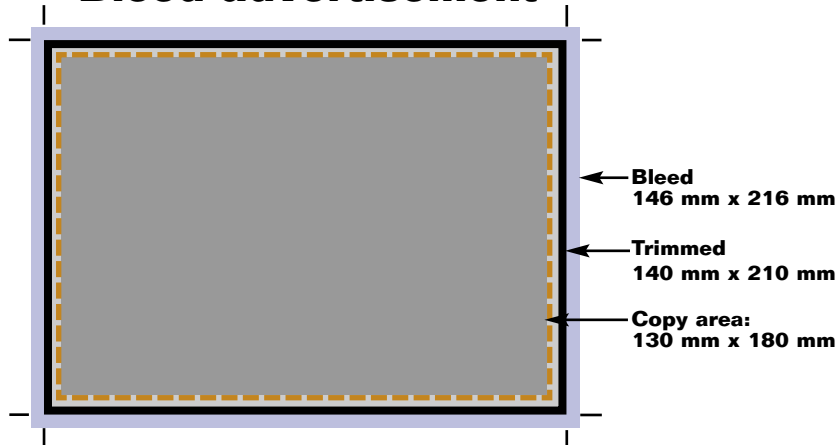

“Floating” advertisement

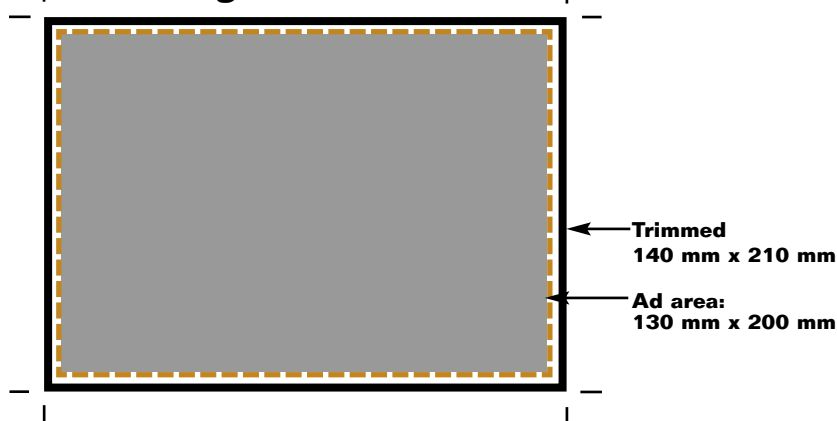

Reproduction material

- **Digital files required** - **PDF** (Closed, all fonts included, press-optimised PDF file, PDF/X-1a:2001)
 - **Tiff** (300 dpi Tiff (CMYK, real advertisement size)
 - **JPG** (300 dpi JPG, highest quality (CMYK, real advertisement size)

Brooke Patrick Publications can ONLY accept these three file types.

- **Crop marks**

All digital files must be supplied with crop marks. Crop marks must show the trim size.

A conversion rate of R350 will be applicable if the advertisements must be re-sized or are supplied without crop marks.

- **Bleed**

All files must have 3 mm bleed.

- **Colour correct proof**

A colour proof of the advertisement must be submitted. Brooke Patrick Publications accepts no responsibility for colour variations in advertisements that are supplied without a colour correct proof.

Advertisement specifications

- Files can be supplied on **CD, DVD, websend** or via **e-mail** (e-mail file not exceeding 8 MB).
- Advertisements can be e-mailed to **dtp@brookepatrick.co.za**

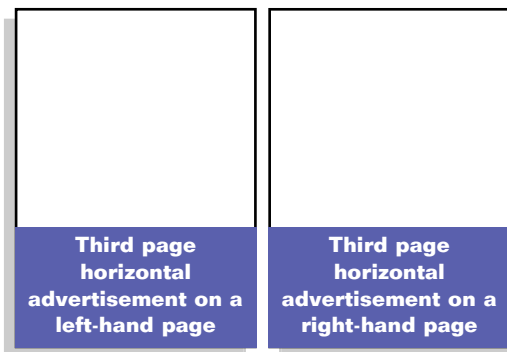

Magazine advertisement

Third page

HORIZONTAL

95 mm x 210 mm

Booking Deadline

1st day of the month prior to the month of publication.

Material Deadline

5th day of the month prior to the month of publication.

BROOKE PATTRICK
P U B L I C A T I O N S

Bleed advertisement

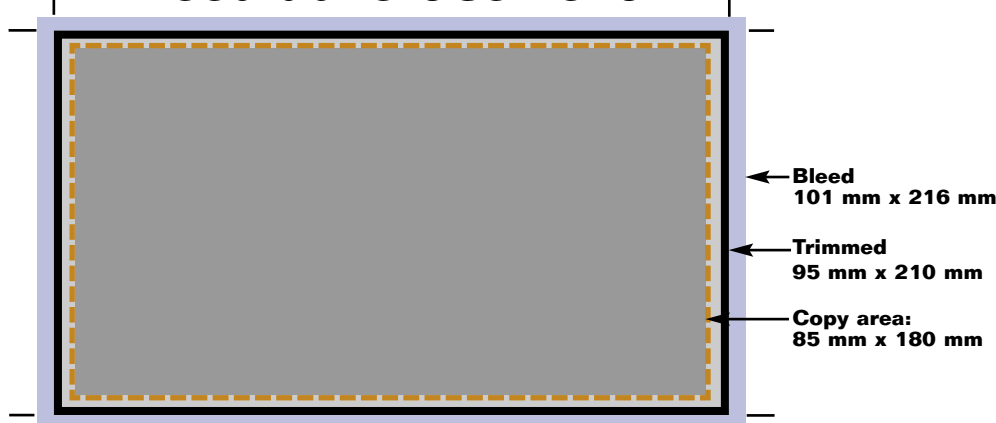

“Floating” advertisement

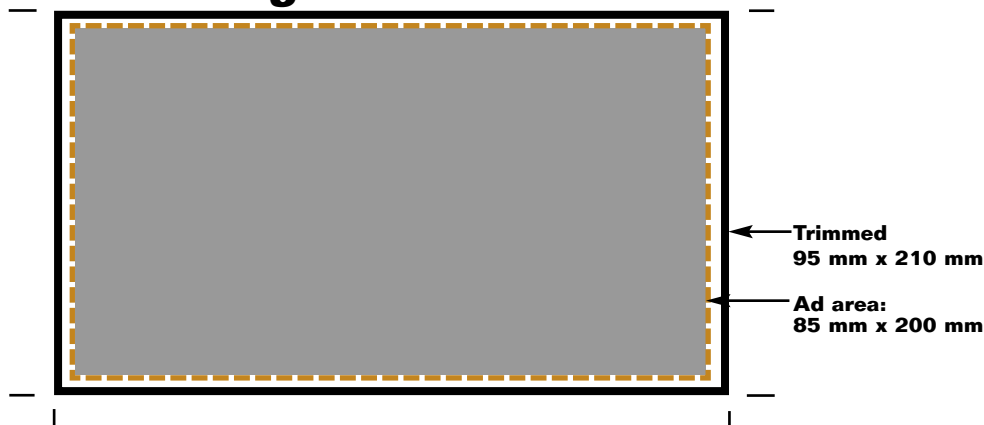

Reproduction material

- **Digital files required** - **PDF** (Closed, all fonts included, press-optimised PDF file, PDF/X-1a:2001)
 - **Tiff** (300 dpi Tiff (CMYK, real advertisement size)
 - **JPG** (300 dpi JPG, highest quality (CMYK, real advertisement size)

Brooke Patrick Publications can ONLY accept these three file types.

- **Crop marks**

All digital files must be supplied with crop marks. Crop marks must show the trim size.

A conversion rate of R350 will be applicable if the advertisements must be re-sized or are supplied without crop marks.

- **Bleed**

All files must have 3 mm bleed.

- **Colour correct proof**

A colour proof of the advertisement must be submitted. Brooke Patrick Publications accepts no responsibility for colour variations in advertisements that are supplied without a colour correct proof.

Advertisement specifications

- Files can be supplied on **CD, DVD, websend** or via **e-mail** (e-mail file not exceeding 8 MB).
- Advertisements can be e-mailed to **ntp@brookepatrick.co.za**

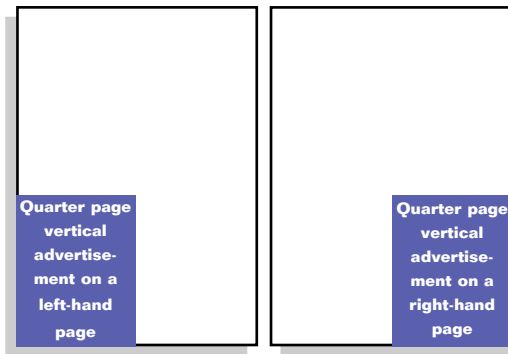

BROOKE PATTRICK
P U B L I C A T I O N S

Magazine advertisement

Quarter page

VERTICAL

140 mm x 100 mm

Booking Deadline

1st day of the month prior to the month of publication.

Material Deadline

5th day of the month prior to the month of publication.

Bleed advertisement

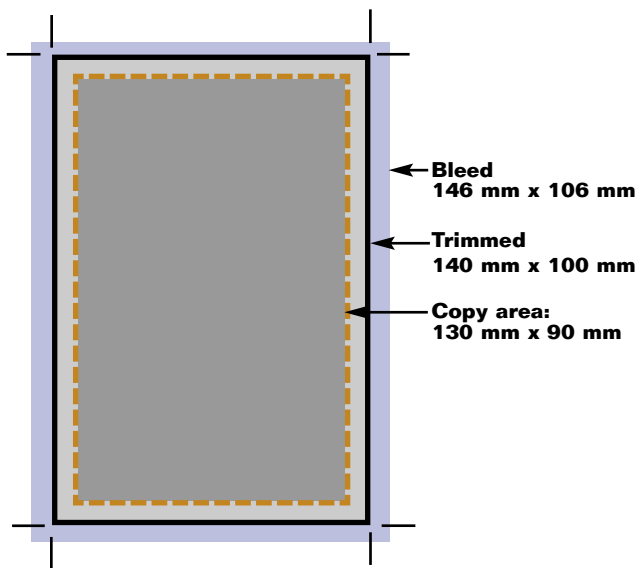

“Floating” advertisement

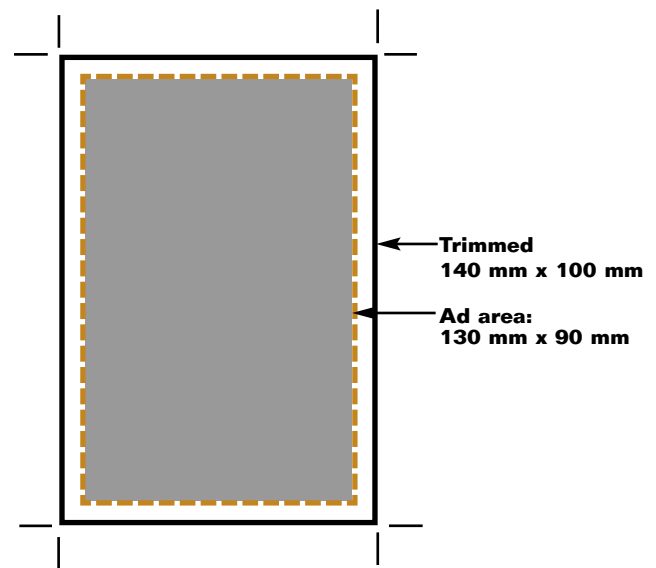

Reproduction material

- **Digital files required** - **PDF** (Closed, all fonts included, press-optimised PDF file, PDF/X-1a:2001)
 - **Tiff** (300 dpi Tiff (CMYK, real advertisement size)
 - **JPG** (300 dpi JPG, highest quality (CMYK, real advertisement size)

Brooke Patrick Publications can ONLY accept these three file types.

- **Crop marks**

All digital files must be supplied with crop marks. Crop marks must show the trim size.

A conversion rate of R350 will be applicable if the advertisements must be re-sized or are supplied without crop marks.

- **Bleed**

All files must have 3 mm bleed.

- **Colour correct proof**

A colour proof of the advertisement must be submitted. Brooke Patrick Publications accepts no responsibility for colour variations in advertisements that are supplied without a colour correct proof.

Advertisement specifications

- Files can be supplied on **CD, DVD, websend** or via **e-mail** (e-mail file not exceeding 8 MB).
- Advertisements can be e-mailed to **dtp@brookepatrick.co.za**

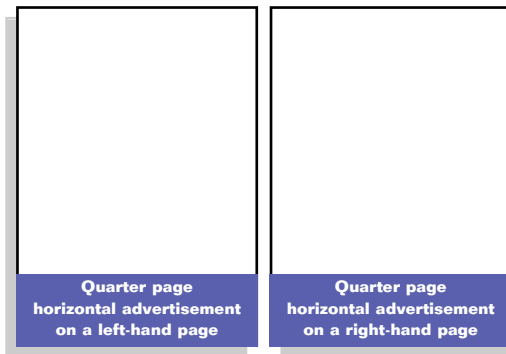

BROOKE PATTRICK
P U B L I C A T I O N S

Magazine advertisement

Quarter Page

HORIZONTAL

70 mm x 210 mm

Booking Deadline

1st day of the month prior to the month of publication.

Material Deadline

5th day of the month prior to the month of publication.

Bleed advertisement

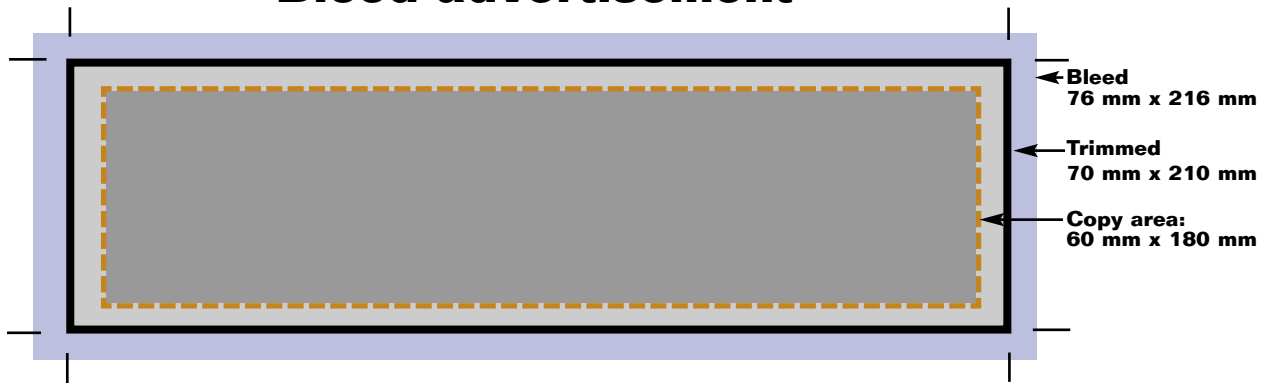

“Floating” advertisement

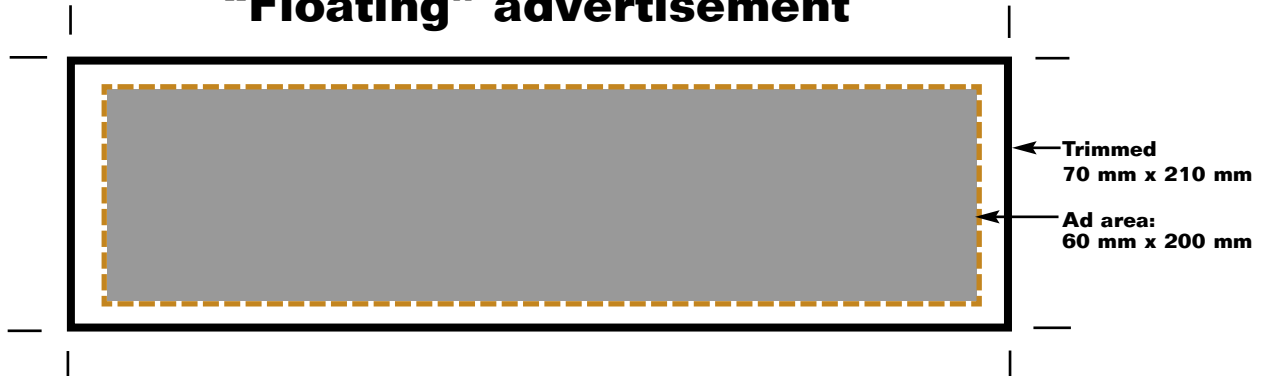

Reproduction material

- **Digital files required** - **PDF** (Closed, all fonts included, press-optimised PDF file, PDF/X-1a:2001)
 - **Tiff** (300 dpi Tiff (CMYK, real advertisement size)
 - **JPG** (300 dpi JPG, highest quality (CMYK, real advertisement size)

Brooke Patrick Publications can ONLY accept these three file types.

- **Crop marks**

All digital files must be supplied with crop marks. Crop marks must show the trim size.

A conversion rate of R350 will be applicable if the advertisements must be re-sized or are supplied without crop marks.

- **Bleed**

All files must have 3 mm bleed.

- **Colour correct proof**

A colour proof of the advertisement must be submitted. Brooke Patrick Publications accepts no responsibility for colour variations in advertisements that are supplied without a colour correct proof.

Advertisement specifications

- Files can be supplied on **CD, DVD, websend** or via **e-mail** (e-mail file not exceeding 8 MB).
- Advertisements can be e-mailed to **ntp@brookepatrick.co.za**

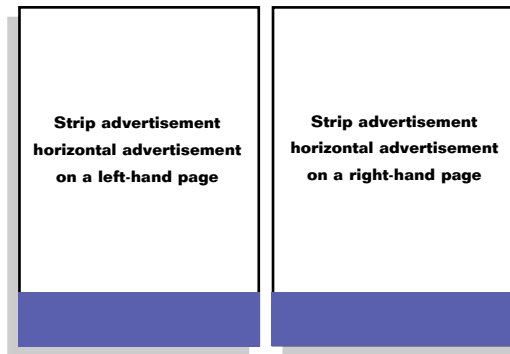

Magazine advertisement

Strip

HORIZONTAL

55 mm x 210 mm

Booking Deadline

1st day of the month prior to the month of publication.

Material Deadline

5th day of the month prior to the month of publication.

BROOKE PATTRICK
P U B L I C A T I O N S

Bleed advertisement

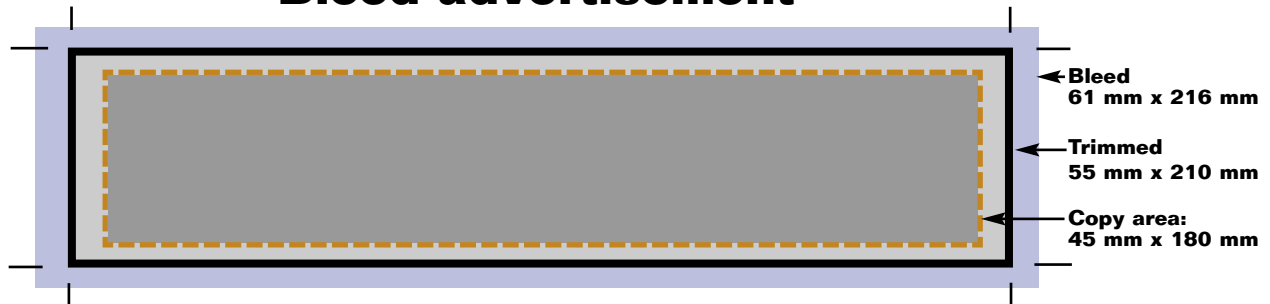

“Floating” advertisement



Reproduction material

- **Digital files required** - **PDF** (Closed, all fonts included, press-optimised PDF file, PDF/X-1a:2001)
- **Tiff** (300 dpi Tiff (CMYK, real advertisement size))
- **JPG** (300 dpi JPG, highest quality (CMYK, real advertisement size))

Brooke Patrick Publications can ONLY accept these three file types.

- **Crop marks**

All digital files must be supplied with crop marks. Crop marks must show the trim size.

A conversion rate of R350 will be applicable if the advertisements must be re-sized or are supplied without crop marks.

- **Bleed**

All files must have 3 mm bleed.

- **Colour correct proof**

A colour proof of the advertisement must be submitted. Brooke Patrick Publications accepts no responsibility for colour variations in advertisements that are supplied without a colour correct proof.

Directory advertisement sizes

Size A

56 mm x 48 mm

Size C

56 mm x 144 mm

Size D

56 mm x 192 mm

Size B

56 mm x 96 mm

Reproduction material

- **Digital files required** - **PDF** (Closed, all fonts included, press-optimised PDF file, PDF/X-1a:2001)
 - **Tiff** (300 dpi Tiff (CMYK, real advertisement size)
 - **JPG** (300 dpi JPG, highest quality (CMYK, real advertisement size)

Brooke Patrick Publications can ONLY accept these three file types.

- **Crop marks**

All digital files must be supplied with crop marks. Crop marks must show the trim size.

A conversion rate of R350 will be applicable if the advertisements must be re-sized or are supplied without crop marks.

- **Colour correct proof**

A colour proof of the advertisement must be submitted. Brooke Patrick Publications accepts no responsibility for colour variations in advertisements that are supplied without a colour correct proof.

Advertisement specifications

- Files can be supplied on **CD, DVD, websend** or via **e-mail** (e-mail file not exceeding 8 MB).
- Advertisements can be e-mailed to **dtp@brookepatrick.co.za**

Bulletin advertisement

Banner

HORIZONTAL

72 dpi

Booking Deadline

1st day of the month prior to the month of publication.

Material Deadline

5th day of the month prior to the month of publication.

BROOKE PATTRICK
P U B L I C A T I O N S

- **Size**

484 x 85 pixels at 72 dpi
(170.7 mm x 30 mm at 72 dpi)
RGB

Reproduction material

- **Digital files required - JPG**
Brooke Patrick Publications ONLY accepts this file type.
- **Size**
484 x 85 pixels at 72 dpi
- **File size**
Less than 120 kB
- **DPI**
72 dpi
- **Colour**
RGB

Advertisement specifications

- Files can be supplied on **CD, DVD, websend** or via **e-mail** (e-mail file not exceeding 8 MB).
- Advertisements can be e-mailed to **dtp@brookepatrick.co.za**

Bulletin advertisement

Bellyband

HORIZONTAL

300 dpi

Booking Deadline
1st day of the month prior to the month of publication.

Material Deadline
5th day of the month prior to the month of publication.

BROOKEPATTRICK
P U B L I C A T I O N S

Bellyband linking to a DPS page in the magazine

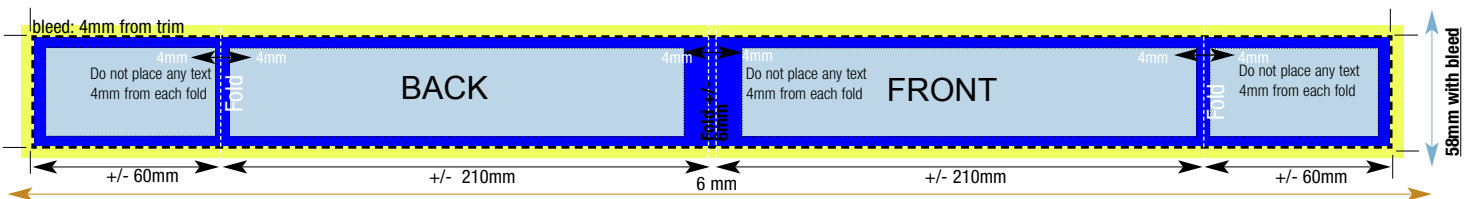

Trimmed size: 546mm x 50mm
Bellyband with bleed: 554mm x 58mm
Bellyband copy area: 538mm x 42mm

- Bleed area
- Size when trimmed
- Copy area

Example of an A4 advertisement with bleed

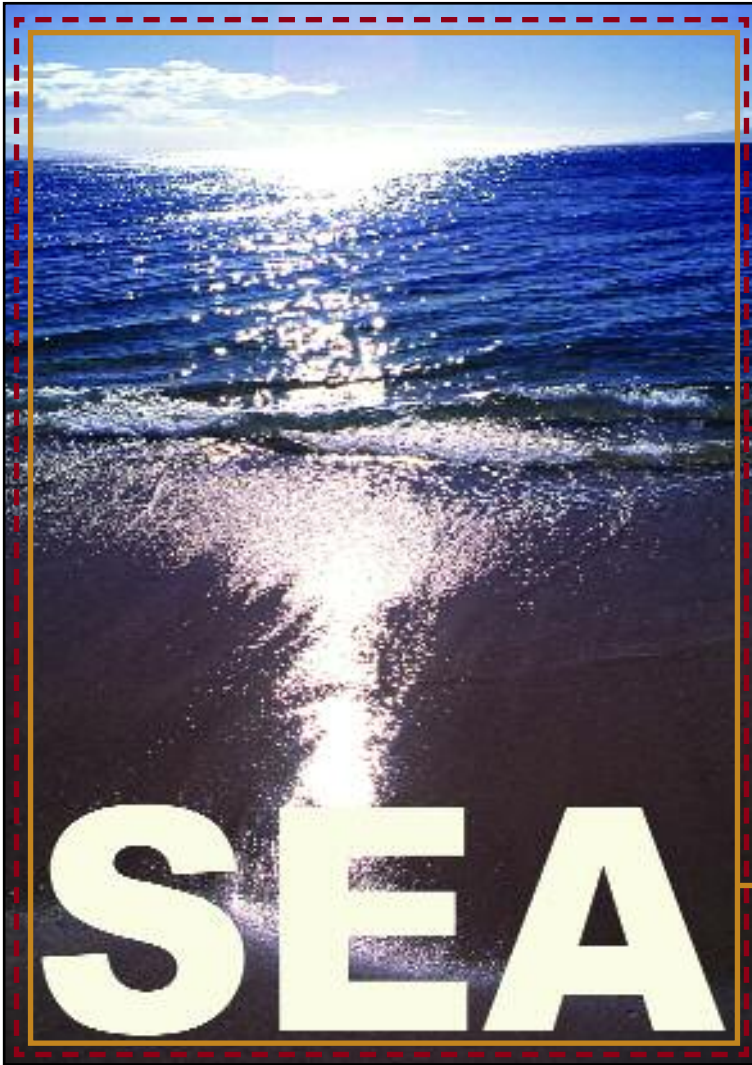

Bleed advertisement

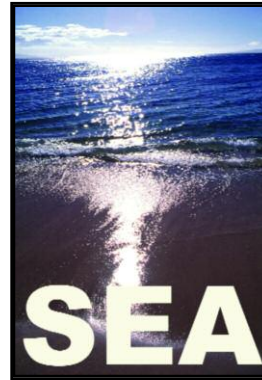

Floating advertisement

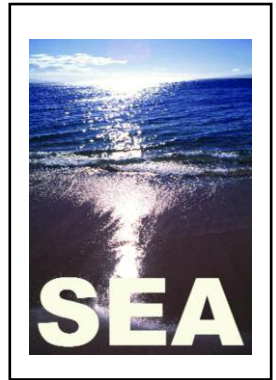

Trimmed size/Booked size

This is the actual size of the advertisement as it will appear in the magazine. In this case it, is an A4, 297 mm x 210 mm.

Bleed

If your advertisement fills the advertisement space in full, and does not have white space around it, it is an advertisement with bleed. All bleed ads **MUST** have 3 mm of bleed surrounding the advertisement. This bleed is necessary so that, when magazines are trimmed, your advertisement "bleeds" (flows) off the page.

Advertisement copy area

Copy should not go outside this space. The copy area must be at least 5 mm inside the trim area. If you place copy outside this area, you run the risk of the copy being trimmed off when the magazines are cut.

Copy too close to the cutting edge

There is a strong chance that the printer may trim your copy.

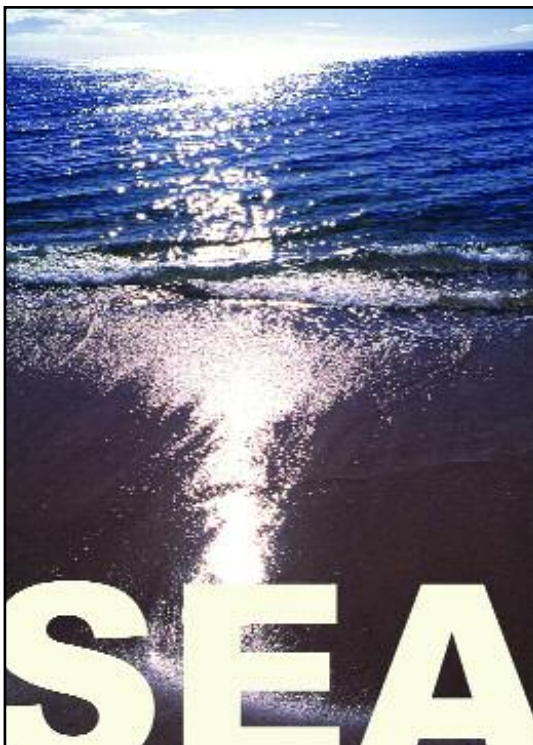

Not enough bleed

You will get "white space" on your ad; the colour will not flow off the page.

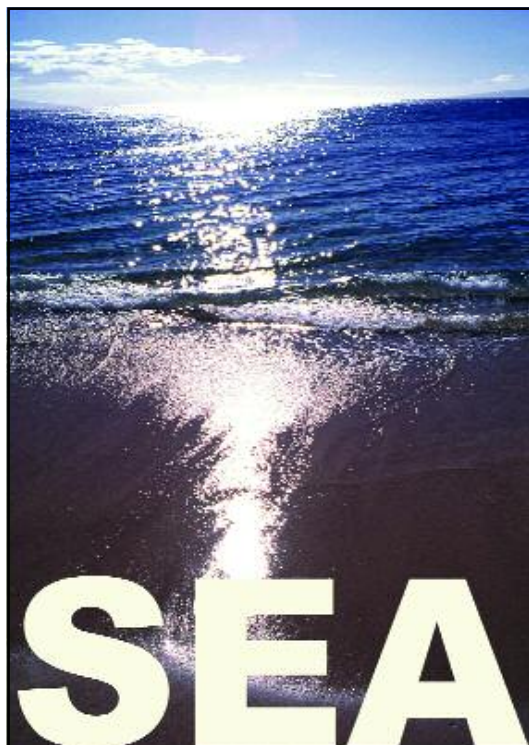

Example of an A4 advertisement without bleed ("floating" advertisement)

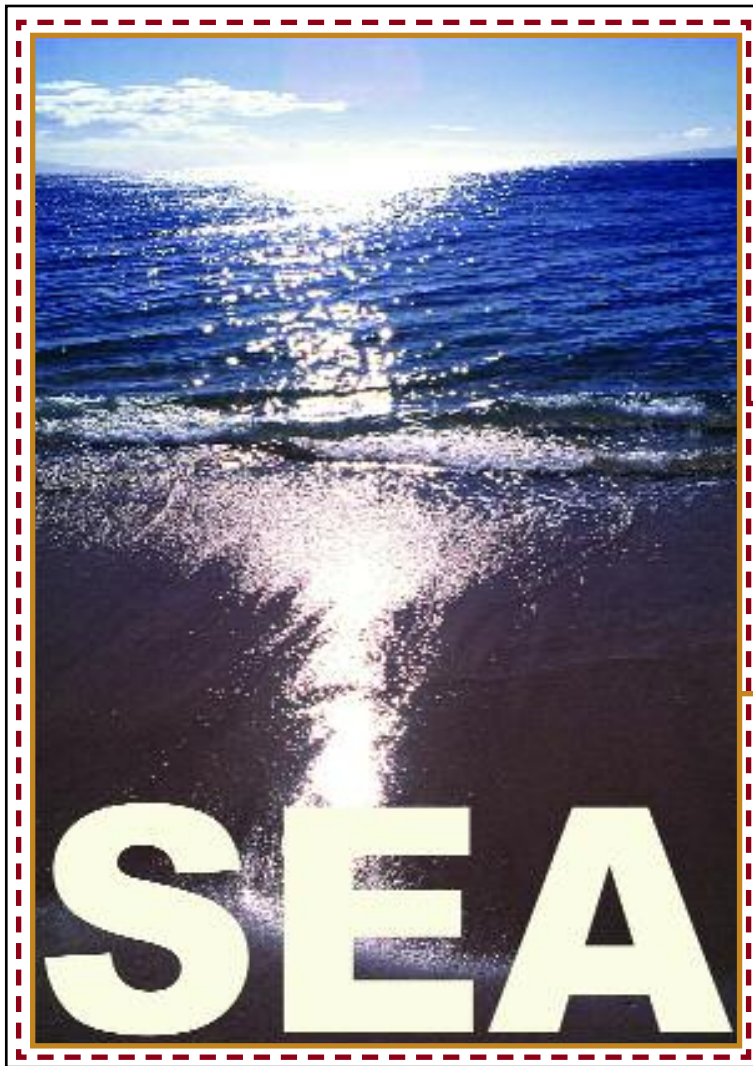

Trimmed size/Booked size

This is the actual size of the advertisement as it will appear in the magazine. In this case, it is an A4, 297 mm x 210 mm.

Bleed

A floating advertisement does not have bleed. There is white space of 5 mm between the advertisement and the trim edge.

Advertisement copy area

Copy should not go outside this space. The copy area must be at least 5 mm inside the trim area. If you place copy outside this area, you run the risk of the copy being trimmed off when the magazines are cut.

A low-res advertisement (bitmapping)



Colour example

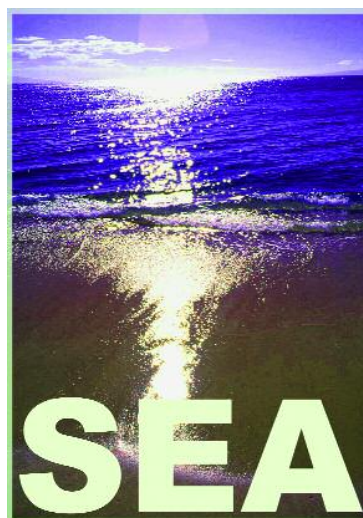

RGB

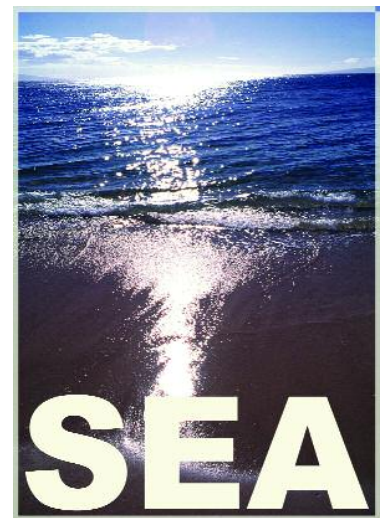

CMYK

We print in CMYK. Most desktop printers print in RGB colour scheme, and the print-out you see is not a true reflection of the advertisement printed in CMYK. The only way to check the colour of your advertisement is to ask your agency for a chromalin.

- A Colour correct proof of the advertisement must be submitted.

Ad make-up 2012

Signed off by Michelle Muller: _____

Date: _____

AD MAKE-UP CHARGE

Total amount: _____

Info for ad make-up

The following to be supplied by client, before ad make-up can start.

- **Headline**
- **Copy for ad**
- **Contact details on the ad**
- **Images**
- **Logo**

MUST BE FILLED

in by sales person

Sales person: _____

Date: _____

Magazine: _____

Issue: _____

Date quotation accepted: _____

Company: _____

Contact name: _____

Cell: _____

E-mail address of client: _____

Client Signature: _____

Make-up of advertisement material

All make-up of new advertisements or alterations to existing advertisements will be charged according to the scale listed below.

DPS

Includes two logo placements, 5 scans and typesetting **R2 050**

Full page

Includes two logo placements, 4 scans and typesetting **R1 650**

Half page

Includes one logo placement, 3 scans and typesetting **R1 350**

Third page

Includes one logo placement, 3 scans and typesetting **R1 250**

Quarter page

Includes one logo placement, 2 scans and typesetting **R990**

Strip

Includes one logo placement, 2 scans and typesetting **R890**

Digital banner advertisement

Includes one logo placement, 2 scans and typesetting **R870**

Directory listing

Includes one logo placement and typesetting **R790**

The above make-up cost includes 2 proofs and a client copy of the material on disc. Any extra changes will be charged as author corrections at an additional hourly rate of R350.

Purchasing photos

Photographs taken by Brooke Patrick Publications may also be purchased.

This is structured in two tiers.

For once off use and third-party repurchases **R650**

For total photographic ownership and exclusivity **R2 350**

Other charges

Chromalin: **R550 A4 or smaller**

Any other additional studio work: **R350 per hour**

Minimum of R250 will be charged for changing addresses and/or contact details on ads that Imibala Studio created

Basic administration costs will be charged at R350 for cancellations after approval.